

MasterMover®

USA Electric Tugger Solutions



MT400+

Master Tug

MasterTug® MT400+

The MasterTug® MT400+ is a single person operated, simple and easy electric tugger which can be used across various applications.

A quick release pin or combi-lock, coupled with the hydraulic lifting mast and hydraulic weight transfer system, allows the MT400+ to lift attached loads of up to 8,800 lb safely.

The automatic tiller cut off, self-adjusting castors and additional anchor points all maximises operator safety and the interchangeable battery ensures the machine is available for use 24/7.

When moving large or oversized loads with the MT400+, the wireless control handset allows a single

Industries

Suitable for use in a wide range of applications and sectors



Plastic and Metal Extrusion



Chemical



Glass



Wind Turbines

KeyBenefits

1 year full guarantee

- Push and Pull any load safely up to 8,800 lb
- Interchangeable battery for 24/7 operation
- Hydraulic Weight Transfer for even weight distribution
- Variable speed controls
- Tiller arm release automatic braking system
- Fully customisable and bespoke couplings
- Available in Stainless Steel

ProductDimensions

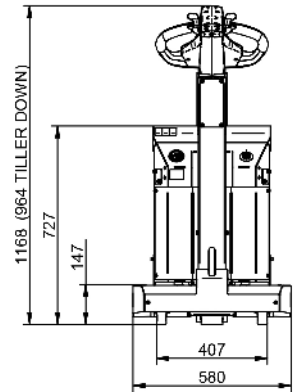
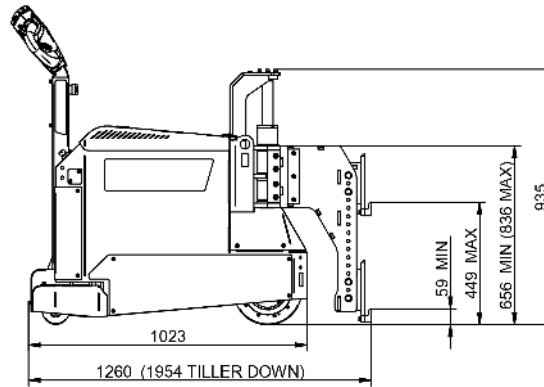
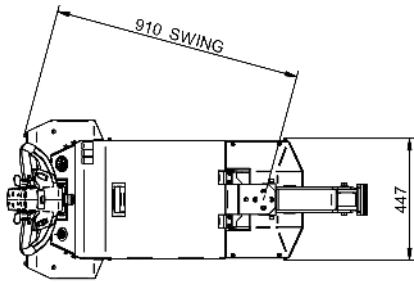

SafetyFeatures

See our website for full technical details



Self-adjusting castor guard for foot protection

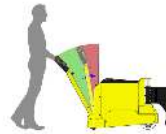

Automatic cut off as tiller arm returns to vertical



Anti-crush button



Emergency stop button

MaxLoadWeight

See our website for full technical details



Castors

Up to 8,800 lb*



Rails

Up to 35,000 lb*

*"Maximum load weight" is only a recommendation that we arrive at by estimating rolling resistance. Your environment and wheel type may affect this figure which is why we carry out a detailed technical evaluation on every project. All of our calculations include a "safe work load" factor to ensure safe operation in all circumstances.

Identification

Product code	MT400+
Recommended load weight - Castors	8800 lbs
Recommended load weight - Rails	35300 lbs
Machine weight including battery	700 lbs
Drive type	Electric AC
Parking brake	Electromagnetic
Drive wheel type	Polyurethane
Drive motor power	1.5 kW
Controller type	AC
Variable machine speed	0.1 mph - 3.1 mph
Ingress Protection	IP44

Battery options

Battery pack - sealed - 102Ah 24V - interchangeable

Battery pack - sealed - 119Ah 24V - interchangeable

Charging options

Charger - external - 10A 24V - 110V-240V

Charger - external - 20A 24V - 110V-240V

Additional equipment

flashing safety light and motion bleeper

two speed selector switch

wireless control handset

Battery protection system

quick release coupling pins

Male coupling options

Coupling - male - height adjustable combi - medium

Coupling - male - height adjustable box - medium

Coupling - channel coupling body

Female coupling options

Coupling - female - combi - medium

Coupling - female - box - medium

To arrange a demonstration, or for further information about our electric tug material handling solutions, please contact us

MasterMover Inc, 8041-J Arrowridge Boulevard, Charlotte, NC 28273, , USA

Telephone Sales: 980-263-2210 Email: sales@mastermover.com

Fax: Website: www.mastermover.com



AboutUs

Located in Charlotte, North Carolina, MasterMover is a business success story with customers all over the world.

Our products are relied upon by market leading organisations and global brands across a broad cross-section of industries including Aerospace, Automotive, Pharmaceutical, Retail and Healthcare.

